

GsmControl+
GSM REMOTE CONTROL

GprsControl+
GSM/GPRS REMOTE CONTROL

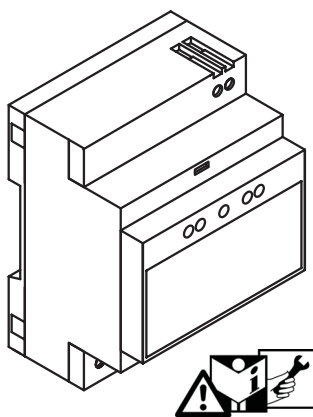

EN USER GUIDE

1012.01.00	GsmControl+A	EMBEDDED ANTENNA
1012.02.00	GsmControl+A	EMBEDDED ANTENNA + BACKUP BATTERY
1012.01.01	GsmControl+X	EXTERNAL ANTENNA
1012.02.01	GsmControl+X	EXTERNAL ANTENNA + BACKUP BATTERY
1012.01.10	GprsControl+A	EMBEDDED ANTENNA
1012.02.10	GprsControl+A	EMBEDDED ANTENNA + BACKUP BATTERY
1012.01.11	GprsControl+X	EXTERNAL ANTENNA
1012.02.11	GprsControl+X	EXTERNAL ANTENNA + BACKUP BATTERY
1012.01.02	GsmControl+DA	EMBEDDED ANTENNA
1012.02.02	GsmControl+DA	EMBEDDED ANTENNA + BACKUP BATTERY
1012.01.03	GsmControl+DX	EXTERNAL ANTENNA
1012.02.03	GsmControl+DX	EXTERNAL ANTENNA + BACKUP BATTERY
1012.01.12	GprsControl+DA	EMBEDDED ANTENNA
1012.02.12	GprsControl+DA	EMBEDDED ANTENNA + BACKUP BATTERY
1012.01.13	GprsControl+DX	EXTERNAL ANTENNA
1012.02.13	GprsControl+DX	EXTERNAL ANTENNA + BACKUP BATTERY

DECLARATION OF CONFORMITY
R&TTE Directive 1999/5/EC

Company identification: Manufacturer: Contrive, Srl
Via Enrico Fermi 18 24040 Suisio Italy

Product identification: Brand: Contrive
Equipment name: GsmControl+ / GprsControl+
Equipment type: GSM/GPRS modem

We declare on our sole responsibility, that the product described above is in compliance with the essential requirements of the 1999/5/CE Directive:

- EN 301 511 GSM900/1800 essential requirements for mobile stations
 - Health and safety requirements pursuant to clause 3.1a:
EN 60950-1 Safety of information technology equipment
 - Protection requirements concerning EMC clause 3.1b:
EN 301 489-1 Electromagnetic compatibility
EN 301 489-7 ElectroMagnetic compatibility and Radio spectrum Matters Specific conditions for mobile and portable radio and ancillary equipments
 - EN 61326 ElectroMagnetic compatibility measurement, control and laboratory use
EN 55024 Information technology equipment - Immunity characteristics
 - Measures for the efficient use of the radio frequency spectrum clause 3.2:
EN 300 607 Radio spectrum matters
- NOTE: Class B equipment (domestic) emission level applied.
Class A equipment (industrial) immunity level applied.

and all tests were carried out

Notified Body: EMCC DR. RAŠEK, GmbH
Moggast, Boelwiese 5
91320 Elbermannstadt Germany



Suisio, Italy February 21, 2006



This product is subject to Directive 2002/96/EC of the European Parliament and the Council of the European Union on waste electrical and electronic equipment (WEEE) and, in jurisdictions adopting that Directive, is marked as being put on the market after August 13, 2005, and should not be disposed of as unsorted municipal waste. Please utilize your local WEEE collection facilities in the disposition of this product and otherwise observe all applicable requirements.

CONTRIVE RESERVES THE RIGHT TO MODIFY THE CHARACTERISTICS STATED IN THIS INSTRUCTION MANUAL AT ANY TIME AND WITHOUT PRIOR NOTICE.

© COPYRIGHT 2002...2005 CONTRIVE SRL ITALY. ALL RIGHTS RESERVED.

SAFETY INFORMATION

- Do not install this unit near medical devices like pacemakers or hearing aids. This unit may interfere with the operation of these devices.
- Switch off this unit when flying. Secure it so that it cannot be switched on inadvertently.
- Do not install this unit near petrol stations, fuel depots, chemical plants or blasting operations when this unit can disturb the operation of technical equipment.
- Interference can occur if this unit is used near televisions, radios or personal computers.
- If the device is coming from a cold environment, then condensation can occur. Before starting operations, the device must be absolutely dry. Thus, an acclimatization period of at least three hours must be observed.
- In order to avoid possible damage, we recommend that you only use the specified accessories. These have been tested and shown to work well with this unit.

This device should be installed only by qualified personnel. Carefully read the instruction manual in its entirety and keep it safe for future reference. It is essential to know the information and comply with the instructions given in the manual to ensure the fitting is installed, used and serviced correctly and safely.

This RF unit is not designed for and intended to be used in portable applications (within 20 cm or 8 inches of the body of the user) and such uses are strictly prohibited.

This unit is not authorized for use as critical component in life-support devices or systems unless a specific written agreement.

If incorrectly installed in a vehicle, the operation of GSM device could interfere with the correct functioning of vehicle electronics. Verification of the protection of vehicle electronics should form a part of the installation. Regulations must be considered to operate a vehicle's light or horn on public roads.

No complex software or hardware system is perfect. Bugs are always present in a system of any size.

In order to prevent danger to life or property, it is the responsibility of the system designer to incorporate redundant protective mechanism appropriate to the risk involved.

All units are 100% functionally tested. Specifications are based on characterisation of tested sample units rather than testing over temperature and voltage each unit.

Contrive disclaims all liability for damage to the fitting or to other property or persons deriving from installation, use and maintenance that have not been carried out in conformity with this instruction manual, which must always accompany the fitting.

PRODUCT DESCRIPTION

The GsmControl+ is an industrial DIN rail GSM modem for the supervision and control of remote inputs and outputs by means of enhanced features available through GSM network.

Industrial standard interface and an integrated SIM card reader mean it can be used rapidly, easily and universally to quickly implement new applications in telemetry, telematics and remote control. All interfaces are integrated in the housing. The connections are suitable for use in domestic and industrial environments.

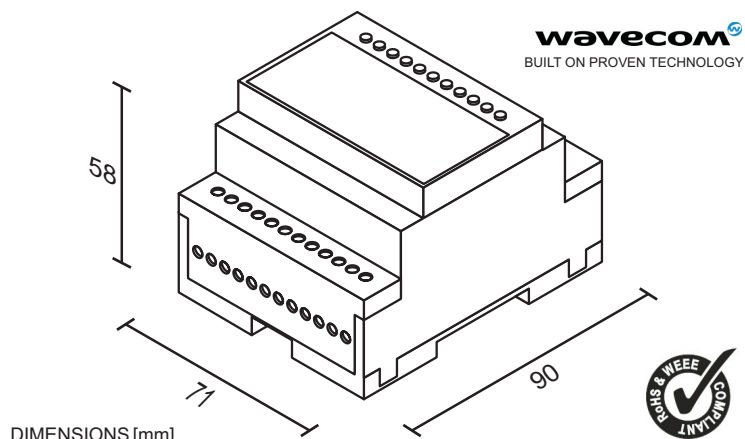

DIMENSIONS [mm]

PRODUCT FEATURES

- Dual band EGSM900 and GSM1800 for data, sms, fax and voice applications Full Type Approved and compliant with ETSI GSM Phase 2+
- Output power: Class 4 (2W @ 900 MHz)
Class 1 (1W @ 1800 MHz)
- Temperature: operating -20 to 55°C
storage and transport -30 to 85°C
- Relative humidity: operating 5 to 95% non-condensing
storage & transport 5 to 95% condensation allowed outside
- Enclosure: EN-50022 rail 4 modules, polycarbonate, UL94 -V0
- Overall dimensions: mm 71 x 90 x 58 (W x H x D)
- Weight: 200 g
- Degree of protection: IP 40 (EN-60529 / IEC 529) properly fitted

CARE AND MAINTENANCE

Your GsmControl is the product of advanced engineering, design and craftsmanship and should be treated with care. The suggestion below will help you to enjoy this product for many years.

- Do not expose the unit to any extreme environment where the temperature or umidity are out of operating range.
- Do not use or store the unit in dusty or dirty areas. Its moving parts (SIM holder for example) can be damaged.
- Do not use chemical cleaning agent on the unit or the SIM card.
- Do not attempt to disassemble the unit or remove any part or label. There are no user serviceable parts inside.
- Do not expose the unit to water, rain or spill beverages. It is not waterproof.
- Do not abuse the unit by dropping, knocking or violently shacking it. Rough handling can damage it.
- Do not place the unit alongside computer discs, credit or travel cards or other magnetic media. The information contained on these devices may be affected.
- This unit is under your responsibility. Please treat it with care respecting all local regulations. It is not a toy. Therefore, keep it in a safe place at all times and out of the reach of childrens.
- Treat the SIM card with the same care as your credit card: do not bend or scratch or expose it to static electricity.
- Try to remember your unlock and PIN codes. Become familiar with and use the security features to block unauthorized use and theft.

Both fixed and mobile applications are allowed, as defined below:

Fixed means that the device is physically secured at one location and is not able to be easily moved to another location.

Mobile means that the device is designed to be used in other than fixed locations and generally in such a way that a separation distance of at least 20 cm (8 inches) is normally maintained between the transmitter's antenna and the body of the user or nearby persons.

Do contact an authorized service center in the unlikely event of a fault in the unit.

INSTALLATION

This unit can be installed on any standard EN-50022 rail by simple snap-in. A minimum protection degree IP40 must be guaranteed, raised to IP54 for open-air application.

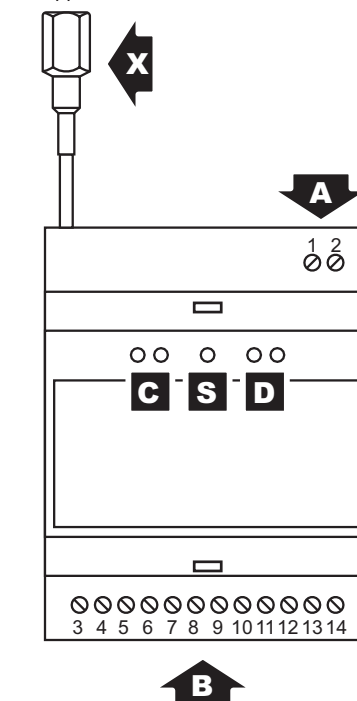

- A. Power Supply input
2 x 2,5mm2 (AWG14)
- B. Input and output terminals
14 x 2,5mm2 (AWG14)
- C. Input red led status indicators
- D. Output green led status indicators
- X. External antenna (type X only)
RG174 + FME male jack
- S. GSM operation LED indicator
 - OFF
No power supply
 - ON
PERMANENTLY
Module switched ON
Not registered on the network, missing SIM or invalid PIN
 - SLOW FLASH
200ms ON / 2s OFF
Module switched ON
Registered on the network
 - QUICK FLASH
200ms ON / 600ms OFF
Module switched ON
Registered on the network
Communication in progress

POWER SUPPLY

- Power supply: 12 V DC ±20% polarity independent
12 V AC ±20%
< 30 mA @ 12 V DC in standby mode
< 100 mA @ 12 V DC in standby mode, relays ON
< 200 mA @ 12 V DC in communication mode
< 1 A @ 12 V DC max peak current
2 x 2.5 mm² (AWG14) screw connector

This unit can be supplied either by alternating or direct current, polarity independent. Power supply connection on terminal 1 and 2, top right side. The power supply unit must meet the demands placed on SELV [1] circuits in accordance with EN60950. The power supply must not be shared with other equipments: suggested power supply source is a simple 12VAC / 5VA transformer. The maximum permissible connection length between device and supply source is 3 m. Overvoltages are suppressed by internal varistor.

[1] Safety Extremely Low Voltage

INPUTS / OUTPUTS

DIGITAL INPUTS

SPST contacts can be connected between terminals 9-10 and 12-13, power supply for contacts is provided by GsmControl. Using electronic switches, terminal 9 and 12 are the positive legs. In order to avoid false triggering, contacts will be considered closed or open after 10+20 seconds from stable condition.

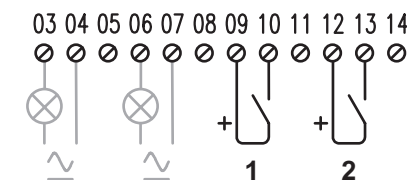

Contact voltage < 20 Vdc
Contact current < 2 mA
4 x 2.5 mm² (AWG14) screw connector

ANALOG INPUTS

Analog signal can be connected to terminals 10 and 13 both are referenced to common ground terminals 11 and 14.

Analog signal circuits must meet the demands placed on SELV [1] circuits in accordance with EN60950.

Using analog inputs, front panel red led indicators [C] doesn't work.

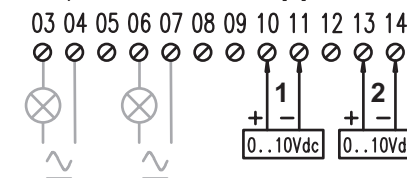

Input voltage range 0...10V [2]
Resolution 10 bits
Accuracy 2%
Input impedance <10 Kohms / 100 nF
Sampling rate 90 Ksps/sec
Sampling time (filtered) 10 sec
4 x 2.5 mm² (AWG14) screw connector

OUTPUTS

Process or appliance can be controlled by means of 2 SPST relay contacts available between terminals 3-4 and 6-7.

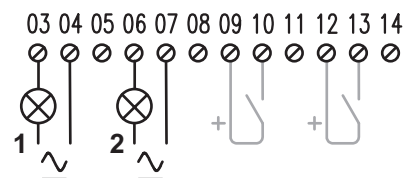

Rated current 4 A
Rated voltage 250 Vac
Max breaking capacity 2500 VA
Minimum contact load 100 mA, 12 V
Cadmium free contacts
Insulation 250 V (IEC60664 / VDE0110b - cat. III / C)
Surge voltage coil contacts: 4000VRMS
Dielectric strength coil-contacts 2500VRMS
open contact circuit 1000VRMS
4 x 2.5 mm² (AWG14) screw connector

[1] Safety Extremely Low Voltage
[2] Place 500 ohm resistor between input and ground to convert to 0...20mA.

ANTENNA

GsmControl+A

The embedded antenna is located under the front panel. This omnidirectional antenna can work properly if the front side of the device is not shielded by metallic frames (i.e.: the GsmControl+A is installed inside a metal cabinet).

GsmControl+X

An external dual-band antenna must be connected to the RF interface, implemented as a 50Ω FME male coaxial jack at the end of a short RG174 cable stub exiting from the top side of the device. The antenna must fulfil the requirements given below:

Frequency TX	880 to 915 MHz	1710 to 1785 MHz
Frequency RX	925 to 960 MHz	1805 to 1880 MHz
Impedance	50 ohms	
VSWR	RX max	1.5 : 1
	TX max	1.5 : 1
Polarization	Linear	
Typical gain	0 dBi in one direction at least	

We recommend a VSWR max of 1.5:1 although a VSWR max of 2:1 can be accepted without affecting performance and certification. The DC impedance is floating but there is no problem when using antennas that present a short to ground.

SIM CARD

The SIM card receptacle is intended for 3V SIM cards [GSM 11.12 phase 2+]. The SIM card must be inserted in the cardholder to put the unit into operation.

Make sure that there is no voltage applied to GsmControl+.

Disconnect also the backup battery, if any. Following the figure below:

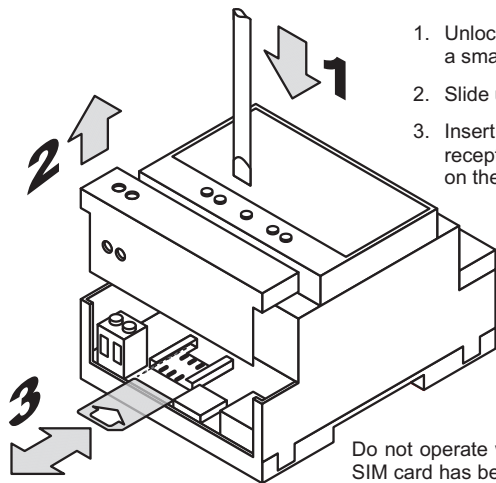

1. Unlock the top cover using a small screwdriver.
2. Slide up the top lid.
3. Insert the SIM card in the receptacle, contacts must be on the bottom side.

To remove the SIM card repeat operations 1 and 2, gently pull the SIM card out.

Do not operate without top cover, once the SIM card has been inserted replace the top lid and then connect power supply.

ACCESS INSIDE

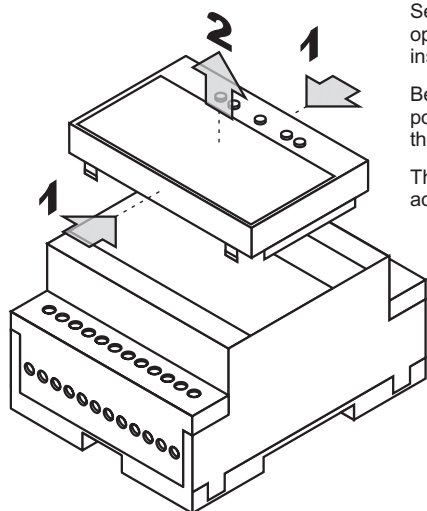

Serial communication port and optional backup battery are located inside the unit.

Before to open the unit disconnect power supply and all live circuits that may be connected.

The front cover must be removed to access the inside of the unit:

1. Push with two fingers on top and bottom sides of front cover to release it.
2. Pull the front cover and keep it in a safe place.

The newer NiMH batteries are less harmful to the environment, have a longer life, and contain recyclable materials. Recycling options available in your local area should be considered when disposing of this product. Do not dispose of in fire.

BACKUP BATTERY

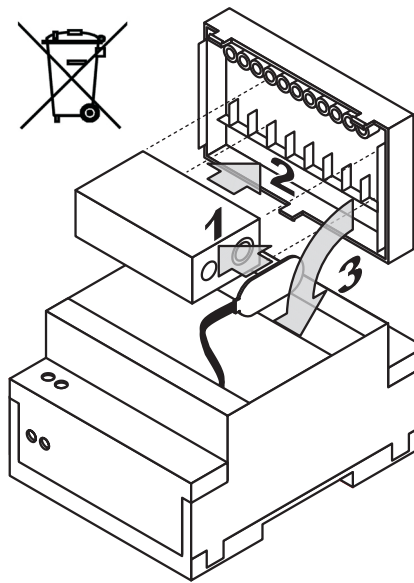

If the unit is provided with UPS feature, a backup battery can be installed to keep the device working even during blackouts. Once the front cover has been removed:

1. Clip the battery to available connector. This connector must be isolated when operating without backup battery.
2. Push the battery into retainer lids located under front cover.
3. Replace the front cover to close the unit.

WHEN USING BATTERIES AND ACCUMULATORS ADHERE TO RELEVANT REGULATIONS

Use only NiMH rechargeable batteries 8.4V or 9.6V type.

COM PORT

ADVANCED CONFIGURATION, LOCAL CONTROL, TRACING AND OTHER FEATURES ARE AVAILABLE THROUGH SERIAL COMMUNICATION LINK

Specific literature and software **GsmSuite** for PC running Microsoft® Windows® are available for free download at www.gsm-control.biz.

Remove the front cover following the instructions to access the RJ45 8 pin modular jack serial interface [P].

Link cable **1013.00.02** is available from local resellers.

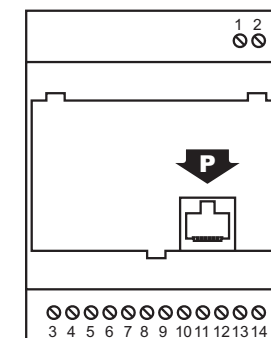

RJ45 PINOUT

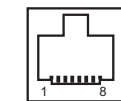

- | | |
|--------|-------|
| 1. GND | DB9-5 |
| 2. RTS | DB9-7 |
| 3. GND | |
| 4. CTS | DB9-8 |
| 5. GND | |
| 6. TxD | DB9-3 |
| 7. GND | |
| 8. RxD | DB9-2 |

Communication: RS-232 (DCE)
300 ... 115200 bit/s
7/8 data bits, 1/2 stop bits, 1 parity bit, 10/11 bit char length
Software handshake, Hardware handshake

SIM PIN



Operating without SIM PIN

The simplest way is to put your SIM card into a cellular phone and program it so it won't ask for the PIN. The SIM card is 'open' and someone could steal the SIM card, use it and read the information inside.



Enter default SIM PIN

GsmControl+ comes with a default PIN = **0000** (four zeroes).

Put your SIM card into a cellular phone and program the PIN using the given number.



Change default SIM PIN

Using com port and **GsmSuite** running on Microsoft® Windows® PC you can modify the default PIN on both GsmControl+ and SIM card.



WARNING

If you insert a SIM card that ask for a PIN number different from that stored into GsmControl+, the device will not operate.

Turning on GsmControl+ for 3 times having mismatch condition, SIM card will lock up and you must provide the PUK (PIN Unblocking Key).

QUICK START

Add Users (group 0)

Remote control is allowed to registered users only.

It's possible to add, modify or delete subscribers from the SIM card phonebook using any GSM mobile phone or SIM card reader/writer.

Following operating instructions provided by phone manufacturer insert the SIM card into the SIM card holder, turn on the phone and scroll the option menu to enter the SIM card Phonebook edit mode.

Enter the users name and telephone number using international format.

Insert the SIM card into the device SIM card holder and turn on the power supply, the unit is ready to operate.

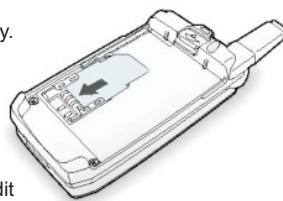

Store first supervisor

Although it's not mandatory to store any supervisor, some special commands will be available only to such kind of subscribers.

To store the first supervisor, once the unit is operative, issue the following SMS:

```
#xxxx.Name.email*
# start character
xxxx system PIN (default = 0000) 4 CHARACTERS
Name supervisor's name to be stored 14 CHARACTERS MAX
email optional email address 40 CHARACTERS MAX
* end character
```

Example: #0000.Harry Potter.harry.potter@hogwarts.com*

The telephone number of SMS sender is automatically collected from the incoming call presentation (thus the telephone number must be kept visible) and will be assumed as the first supervisor's telephone number.

First supervisor will be stored at position 401 and the unit will send back a confirmation or error SMS.

Dots are allowed ONLY within the email address field.

It's possible to use both ? and @ characters before the domain name.



SMS delivery failure is usually less than 1% but you must keep in mind that a message could not arrive and you cannot complain with your operator for this. **GsmComfort+ deletes any pending SMS at power-on.**

DEVICE INFO

To improve the readability of information sent by this device it's suitable to provide some specific information: a supervisor can issue the following SMS:

```
+3,300,tel,info,,,,,email,text
```

tel	Device own phone number	20 CHAR MAX	[1]
info	Short description	14 CHAR MAX	
email	Optional device own email address	40 CHAR MAX	[2]
text	Detailed device application info	56 CHAR MAX	

Example: +3,300,,Building 1,,+4456789,,,,,Apt. 5 living room

info and text will be shown within status SMS sent by this unit.

[1] Device phone number (always in international format) will be used to perform real time clock autosync, missing this field the real time clock is unreliable and SMS commands involving date field will be rejected.

[2] All email issued from Gprs type unit will be sent carbon copy also to its own mailbox if a valid address is provided.

SMS CONTROL

Any registered user can control outputs by means of SMS.

Following default commands can be changed to any custom text using **GsmSuite**. More details available on "Advanced Manual".

S1	Set output 1 ON	[3]
S2	Set output 2 ON	[3]
R1	Reset output 1 OFF	
R2	Reset output 2 OFF	
M1	Set output 1 ON and LATCH (set again at further power on)	[4]
M2	Set output 2 ON and LATCH (set again at further power on)	[4]
D	Status SMS request	
B	Ringback request once command has been processed	

Commands will be recognized both uppercase, lowercase and mixed, nested within other text wherever placed inside the incoming SMS. Multiple commands into same SMS are allowed.

[3] Specifying a time interval after the set command, outputs will be released once set time has been elapsed. If a blackout occur the remaining time is missing, thus the output will be released. Command syntax:

```
Siddhhmm dd days 00+99
hh hours 00+23
mm minutes 00+59
```

[4] Specifying date/time after the set and latch command, outputs will be released at specified expiry date/time. Output status will be recovered after blackout providing the real time clock sync has been performed successfully.

```
M1ddmmyyhhmm dd day 01+31
hh month 01+12
hh year 00+99
hh hours 00+23
mm minutes 00+59
```

Example: S1000830 M22504061230_text D alien trailer
turn ON output 1 for 8 hours and 30 minutes,
turn on and latch output 2 until April 25, 2006 12:30
send back a status SMS

```
s2 text M1 alien trailer B
turn ON output 2,
turn on and latch output 1, ringback
```

STATUS SMS

Following a typical status SMS issued on request:

Building 1	Short description
door control unit	Detailed device application info
Out1:off	output released
Out2: on 00:01:22	remaining time to output off
In 1 : 3.14 V	measured voltage (analog mode input)
In 2 : open	input open
Clip:pulse on	clip mode and status
Blackout	Main power failure detected

Out 1 / 2 status: off output inactive
on output active, remaining time to disable could follow
!on output active and latched
| reverse or pulse clip sequence in progress

In 1 / 2 status: open input open, inactive
close input close, active

FREE CLIP CONTROL

Registered users can control outputs by means of simple (free) calls. Supervisors can set different activation times and outputs behaviour issuing an SMS:

```
+2,290,,,pulse,rev1,hold,rev2,answ,mode
```

pulse	On time	01 + 60" default 3"
rev1	Out1 ON time in reverse mode	01 + 60" default 3"
hold	Hold time in reverse mode	01 + 600" default 3"
rev2	Out2 ON time in reverse mode	01 + 60" default 3"
answ	Time to answer in toggle mode	01 + 60" default 15"
mode	none, pulse, toggle, reverse, dtmf	

NONE

Clip feature is disabled, nothing happens on incoming calls from registered users.

PULSE (default)

Selecting this mode, incoming voice call from registered user will turn on out 1 for the time set in pulse. A non voice (fax or data) call will do the same on out 2.

TOGGLE

Incoming voice calls will toggle out 1 on to off or vice-versa, non voice calls will do the same on out 2. A ringback will be issued only when an output is turned on. If the user waits online, after the time specified in answ GsmControl+ will answer, playing a low tone after output release or four high tones after output activation. No ringback will be issued in such case.

REVERSE

This mode involves both outputs. Any incoming call from registered users will start a sequence: out 1 will be activated for the time specified in rev1, after the delay set in hold, out 2 will be activated for the time specified in rev2.

DTMF

GsmControl+ will answer to incoming call from registered users that, after a short welcome tone, can type the command code on the phone keyboard. Following default commands can be changed to any custom one using **GsmSuite**.

1	2	3
OUT1 ON	OUT2 ON	-
4	5	6
OUT1 OFF	OUT2 OFF	-
7	8	9
OUT1 LATCH	OUT2 LATCH	-
*	0	#
CONFIRM	STATUS	DELETE

Once all commands are issued, confirm the execution typing * (star) key. Using # (hash) key is possible to delete everything and start from the beginning.

Correct commands will be confirmed by four short high tones. Wrong commands will produce a long low tone.

SYSTEM COMMANDS

Special control SMS are reserved to supervisors only:

Stop

Disable free calls control feature (CLIP): incoming calls will be rejected.

Start

Enable free calls control feature (CLIP): incoming calls from registered users will activate outputs following the specified sequence.

List###

An SMS reporting the list of last ### (1+999) calls will be sent. List is always limited to the SMS max length of 160 characters. The full list will be sent specifying 0.

Pbook

An Email reporting the complete phonebook will be issued to supervisor's email address, if any (GPRS only).

Pbook++

An Email reporting the complete phonebook and all system settings will be issued to supervisor's email address, if any (GPRS only).

ADVANCED CONFIGURATION

Using GsmSuite is possible to configure advanced features, either linking the unit with local com port or issuing SMS in remote mode. Refer to GsmSuite help file or Advanced Manual for detailed information. Most important advanced features:

Add / edit Recipients (group 9)

Alerts following local events can be issued to Recipients (up to 100).

Add / edit Supervisors (group 7)

Up to 100 supervisors can be stored inside the unit.

Add / edit Users (group 0 / group 1)

Users can be stored into SIM card phonebook. Conditional users (having more features) can be stored into device memory.

Delete Phonebook entries

Remove any entry from phonebooks by means of GsmSuite or issuing an SMS.

GPRS / Email settings

Emails service configuration, available for GPRS devices.

Scheduled operations

Activities to be performed on a time basis (up to 100).

THE INFORMATION CONTAINED IN THIS DOCUMENT ARE SUBJECT TO CHANGE WITHOUT NOTICE. PRODUCT NAMES, CORPORATE NAMES OR TITLES USED WITHIN THIS DOCUMENT MAY BE TRADEMARKS OR REGISTERED TRADEMARKS OF OTHER COMPANIES AND ARE MENTIONED ONLY IN AN EXPLANATORY MANNER TO THE READERS' BENEFIT, AND WITHOUT INTENTION TO INFRINGE.

WHILE EVERY EFFORT HAS BEEN MADE TO MAKE SURE THE INFORMATION IN THIS DOCUMENT IS CORRECT, CONTRIVE CAN NOT BE LIABLE FOR ANY DAMAGES WHATSOEVER FOR LOSS RELATING TO THIS DOCUMENT.

WARRANTIES

CONTRIVE GUARANTEES FOR TWO YEARS FROM THE DATE OF MANUFACTURE OF ITS PRODUCT TO REPLACE, OR, AT ITS OPTION, TO REPAIR ANY PRODUCT OR PART THEREOF WHICH IS FOUND DEFECTIVE IN MATERIAL OR WORKMANSHIP OR WHICH OTHERWISE FAILS TO CONFORM TO THE DESCRIPTION OF ITS SALES ORDER. CONTRIVE MAKES NO WARRANTY OF MERCHANTABILITY OR ANY OTHER WARRANTY EXPRESS OR IMPLIED. IN NO EVENT SHALL CONTRIVE BE LIABLE FOR CONSEQUENTIAL OR SPECIAL DAMAGES OF ANY NATURE WHICH MAY ARISE IN CONNECTION WITH SUCH PRODUCTS.

THE WARRANTY DOES NOT APPLY IN CASE OF IMPROPER USE